

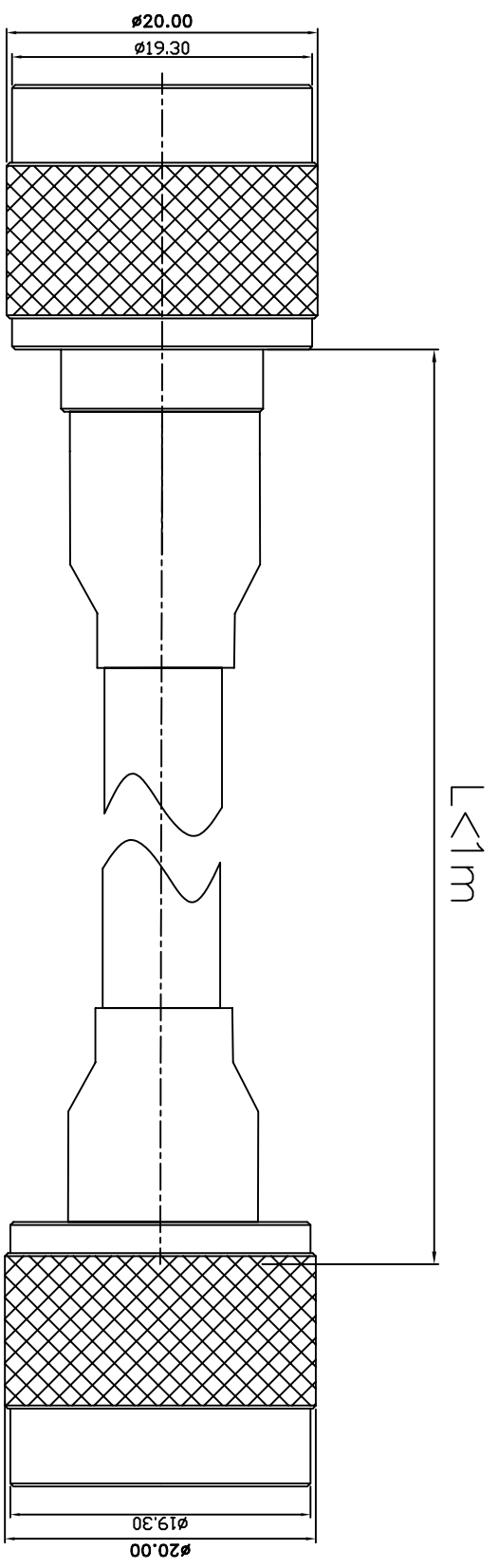

REV	DESCRIPTION	DRAWN	DATE



NO	Description	Qty	Material	Finish
3	N-1101-7-B4-TGN	1	BRASS	NICKEL
2	LOW LOSS 400	1		
	N-1101-7-B4-TGN	1	BRASS	NICKEL

1 REMOVE ALL BURRS	*MAJOR DIMENSION
2 BREAK ALL CORNERS & EDGES CO.15 MAX.	UNLESS OTHERWISE NOTED TOLERANCES
3 CHAMFER 1ST & LAST THREADS 45°	0.5-6=±0.2
4 DIAMETERS ON COMMON CENTERS TO BE CONCENTRIC WITH DIMENSIONS ARE	6-30=±0.4
5 AFTER PLATING.	30-120=±0.6
	120-315=±1.0
	ANGLES=±1°

APPROVED	CHECKED
DRAWN	DRAWN
	PEN
DRAWN DATED 05/05/04	

 華耀科技有限公司 <i>Hua Yao Technologies co.,Ltd</i>	TITLE N1101-N1101
DRAWING NO. 1101740011017-1L	REV A
FILE NO. D:\DWG\N1101-N1101\1101740011017-1L	